

**DIAMONDCUT-500**

**Features**

- > High precision, bench-top automatic cutting machine
- > Suitable for non-deforming materials cutting such as metals, electronic parts, ceramic, hard alloys
- > High cutting accuracy and wide speed adjusting range
- > Both diamond and resin cutting discs can be used
- > Equipped with a LCD display with menu operation, large cutting chamber and safety protections
- > Cutting table provided with T-slots to assemble different vices
- > Built-in recirculating cooling system with external magnetic separator

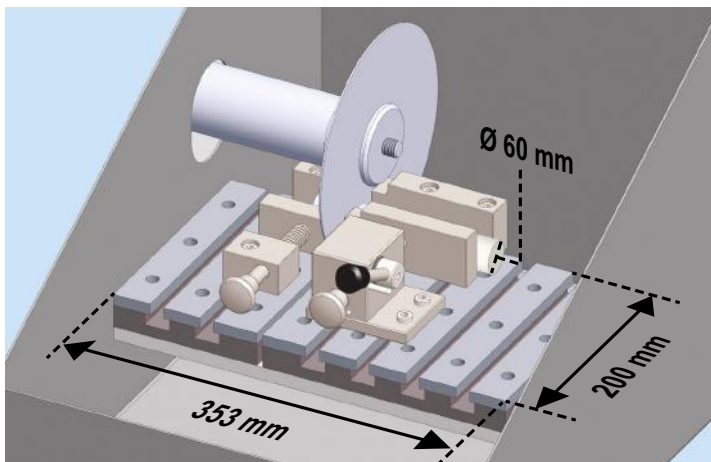

Model	DIAMONDCUT-500	
Cutting capacity	Max. ø 60mm	
Cutting disc diameter	100; 125; 150; 200mm	
Y axis travel	200mm	
Noise level	55dB	
Working chamber LxW	500x400mm	
T-slots table LxW	320x225mm, T-slot 12mm	
Speed	500÷3000rpm	
Feeding speed	0÷180mm/min (0.1mm increments)	
Operating temperature	-10÷50°C	
Humidity non-condensing	95%	
Motor power	1500W	
Power supply	230V ±10% - 50/60Hz - 1Ph	
Cooling tank	Capacity	36l
	Dimensions	300x500x450mm
	Weight	20kg
Machine	Dimensions	850x770x460mm
	Weight	140kg

**Standard accessories**

Quick clamp jaw height 45mm; hexagonal keys; diamond cutting disc 200x1x32mm; cooling system complete with pipes